

# laevo



EN

## V2.56

Wearable back support  
for repetitive bending and  
bended posture

### Quick Guide

August 2020

For USA and Canada

# Safety instructions & application

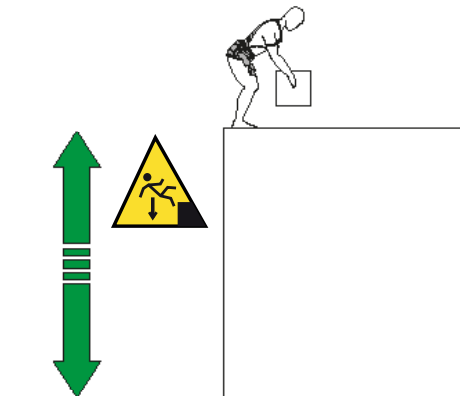
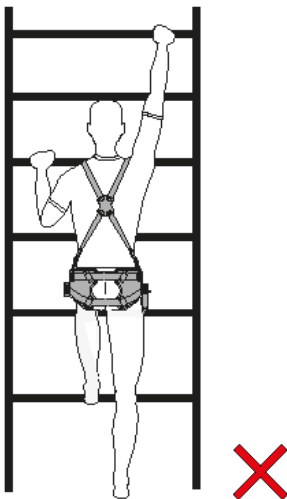
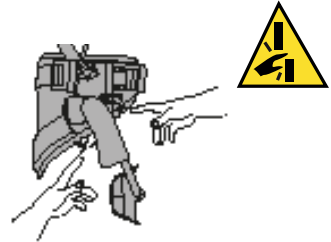
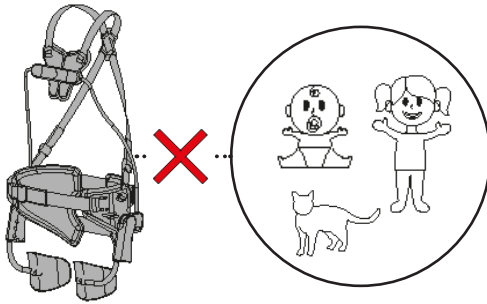
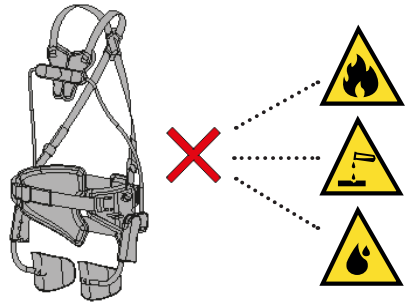
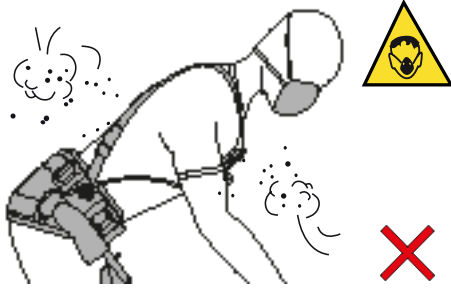

# Installation

## QG-1

EN

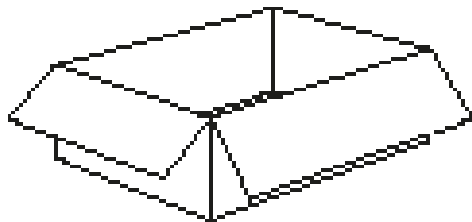

1X



1X

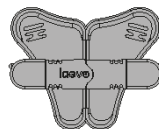

1X

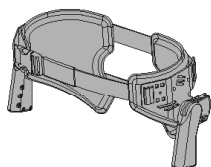

1X

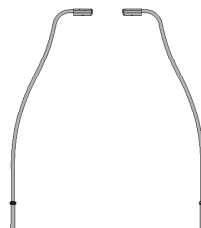

8X



Left + Right

1X



1X

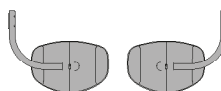

Left + Right

# Installation

## QG-2

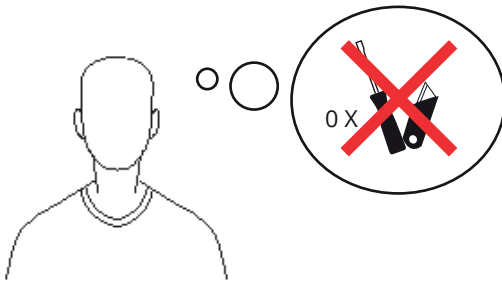
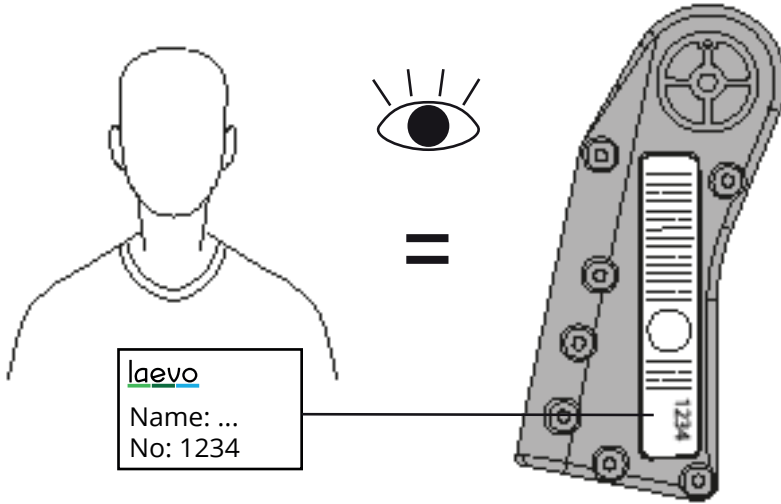

### Disclaimer

Product images may vary slightly depending on model

# Installation

\*\*\*V2.57 model only\*\*\*

## QG-3

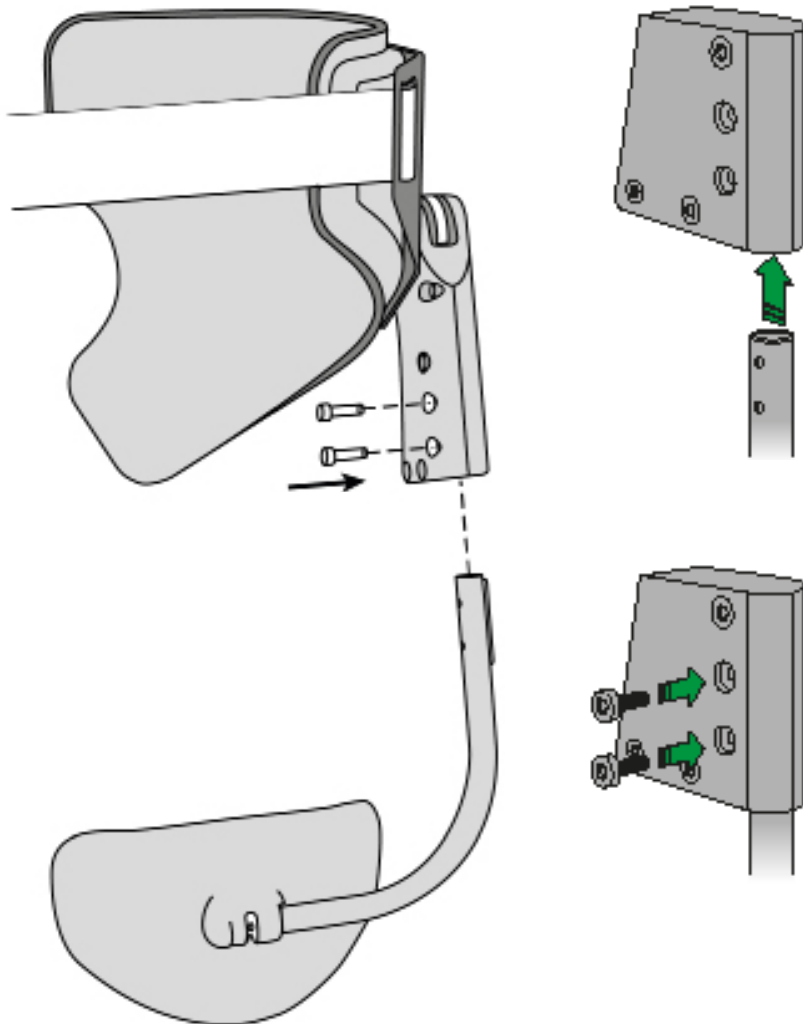

EN

# Installation

## QG-4

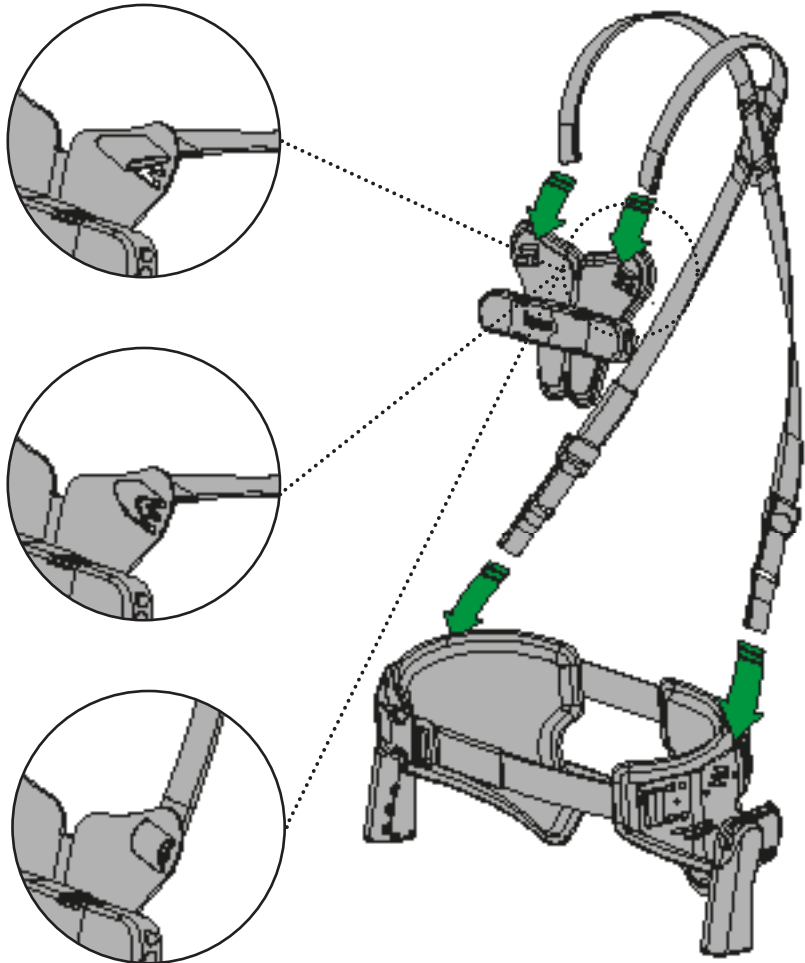

# Installation

QG-5

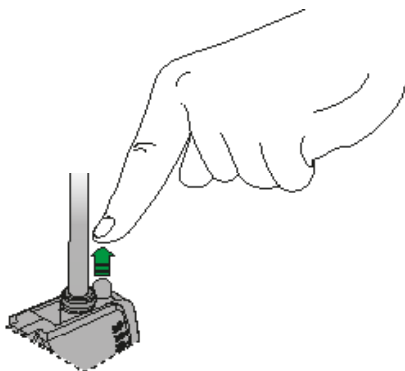
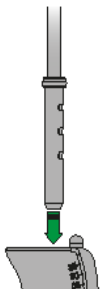
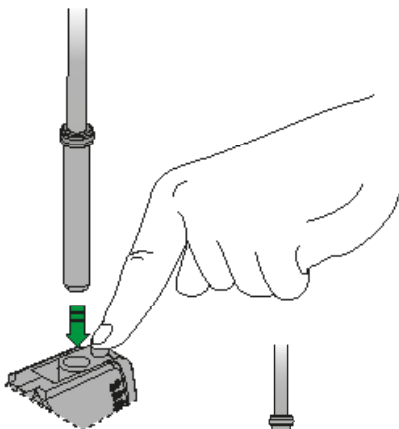
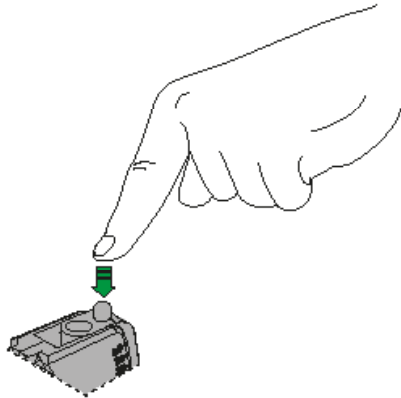
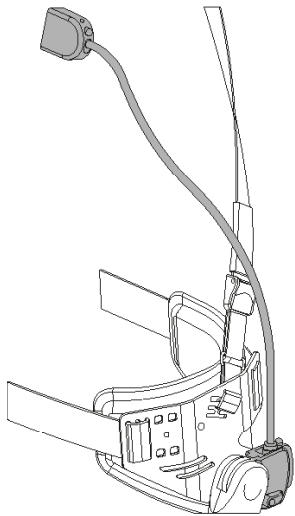

EN

# Installation

QG-6

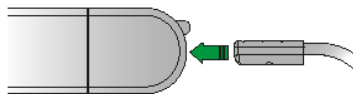
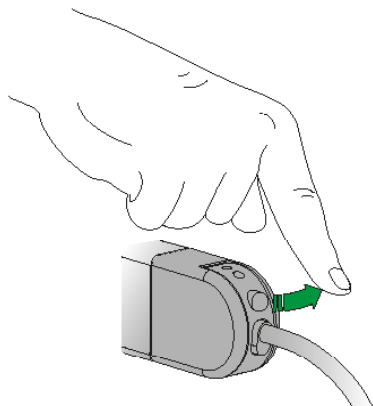
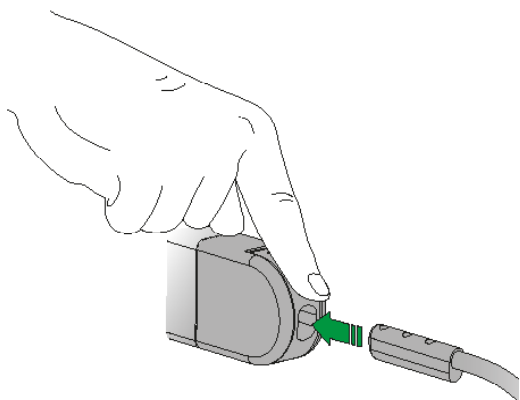
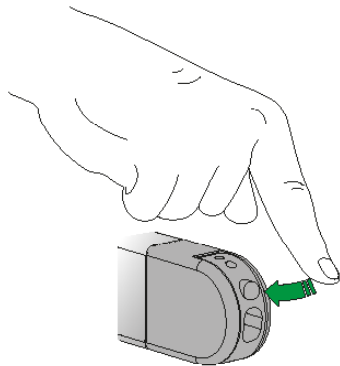
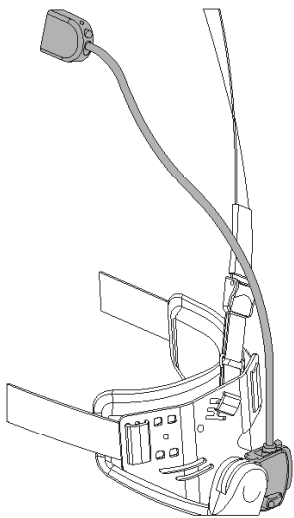



# Fitting

## QG-7

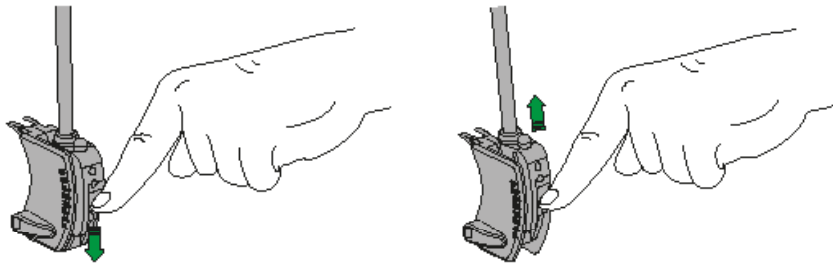

## QG-8

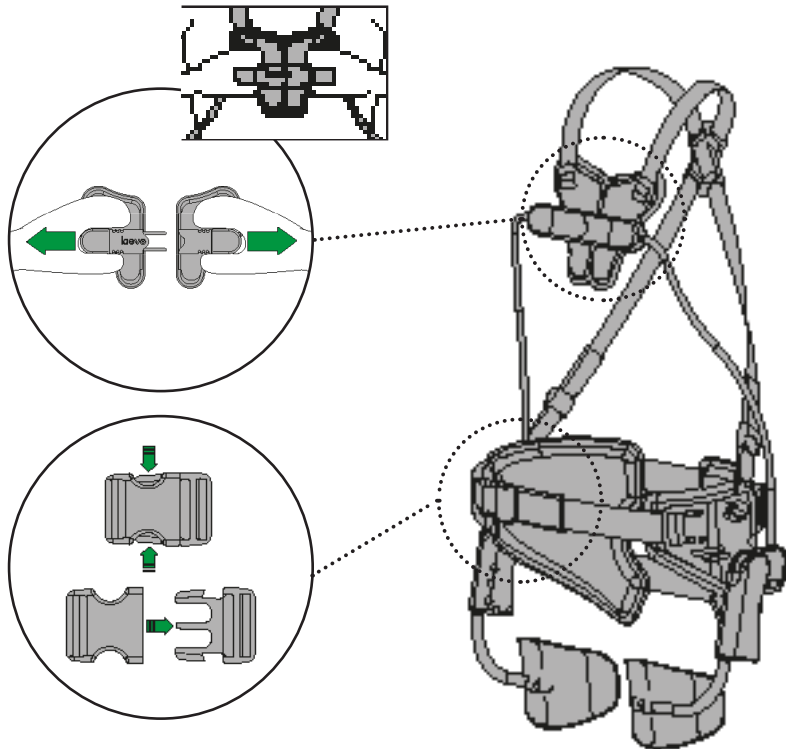

EN

# Fitting

QG-9

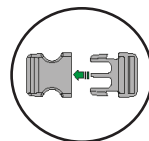
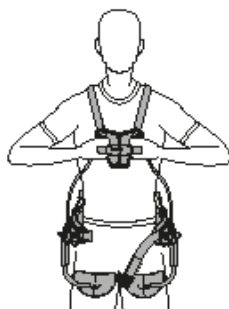
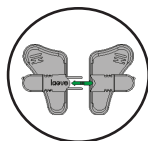
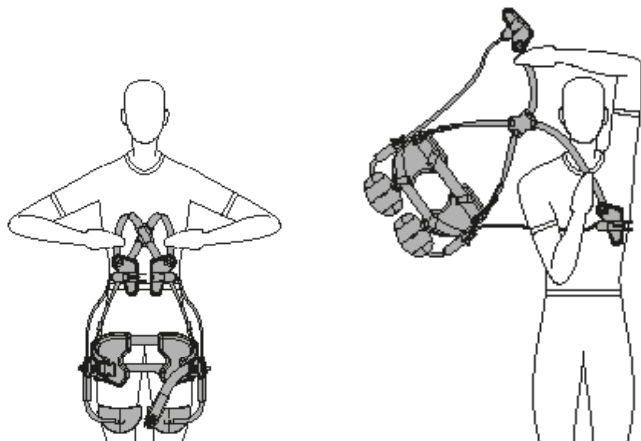

# Fitting

QG-10

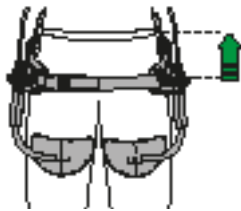

EN

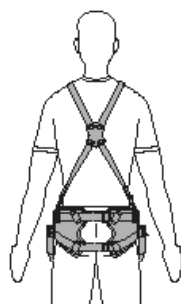
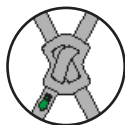
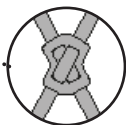
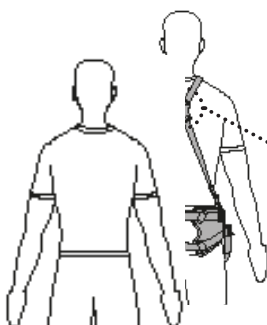
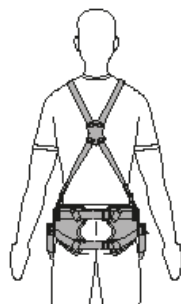
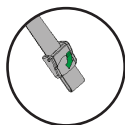
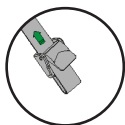
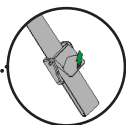
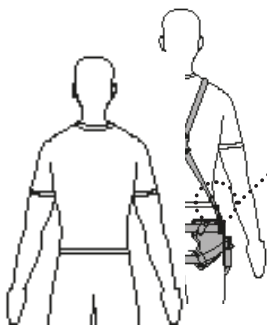

# Fitting

QG-11

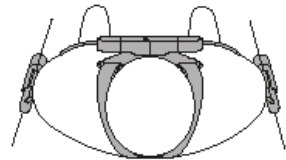
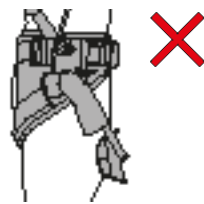
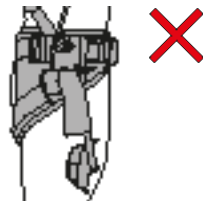
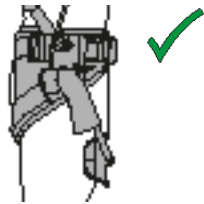
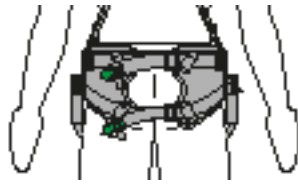

# Fitting

QG-12

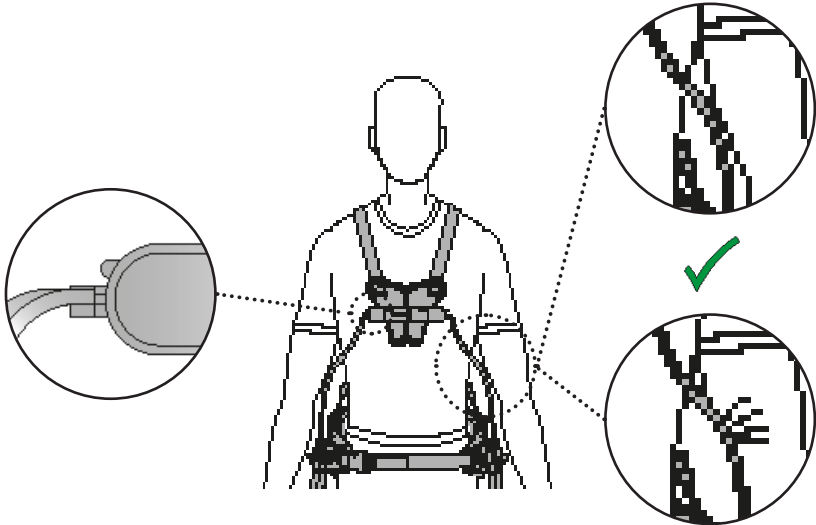

QG-13

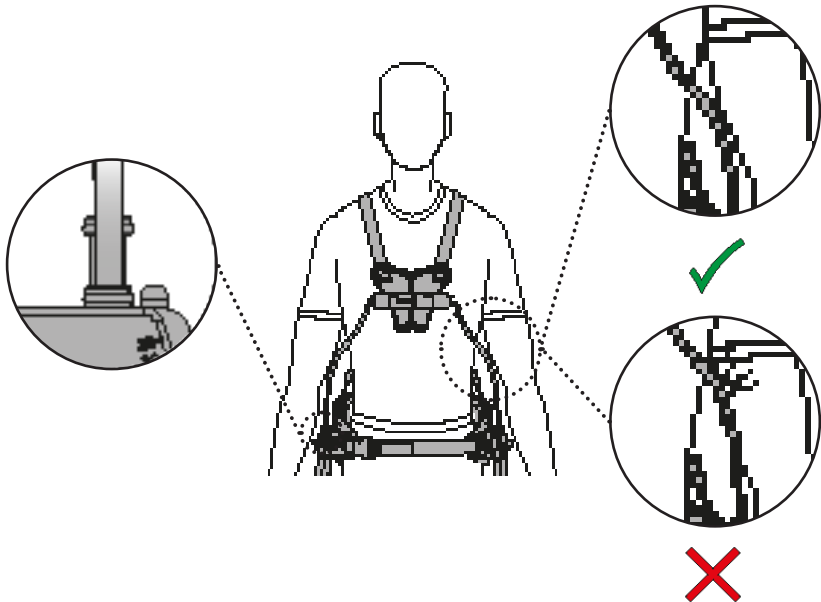

# Fitting

QG-14

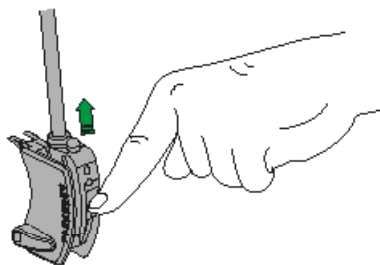
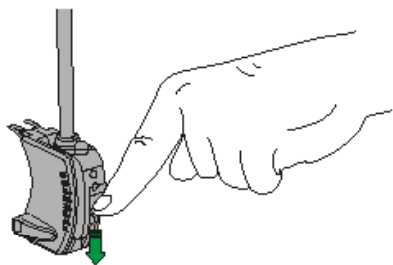
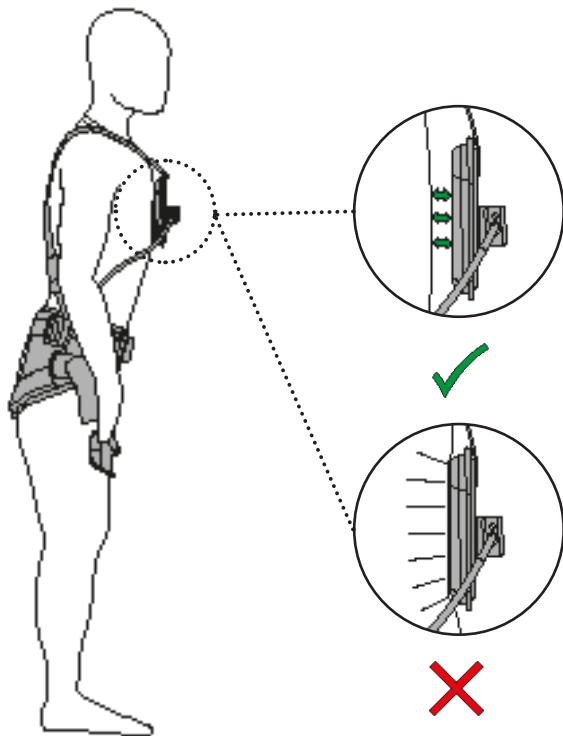

# First use

QG-15

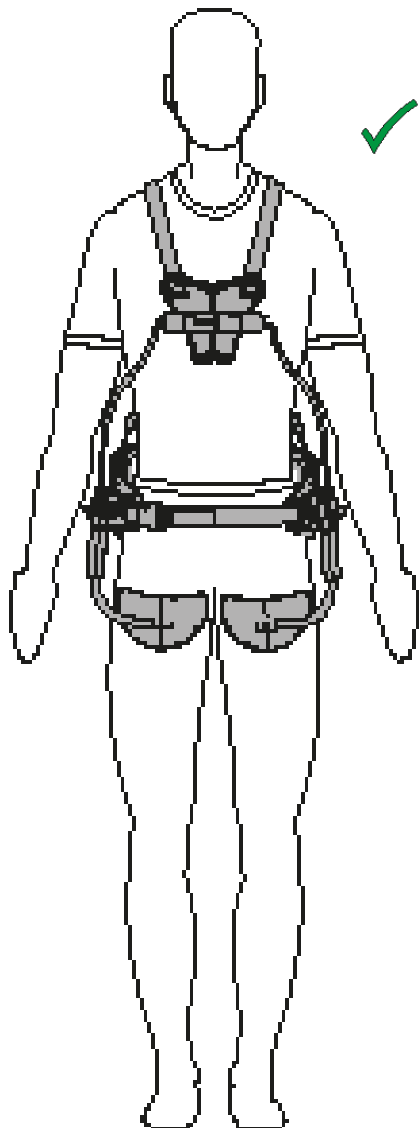

QG-16

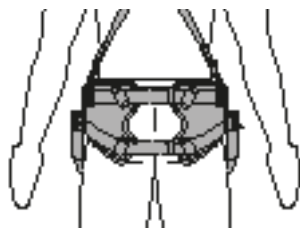
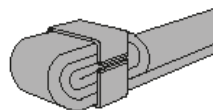
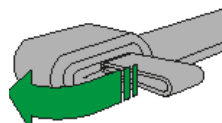
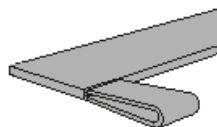
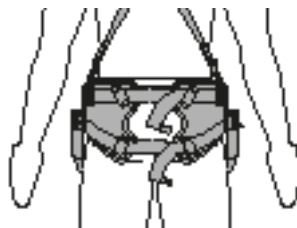

EN

# Checks

## QG-A

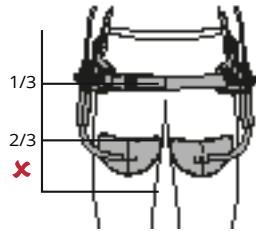
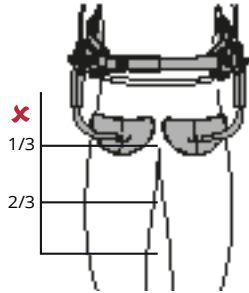
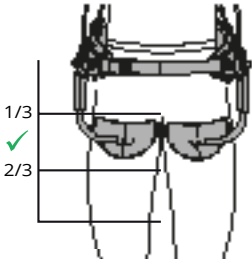



# Checks

QG-B

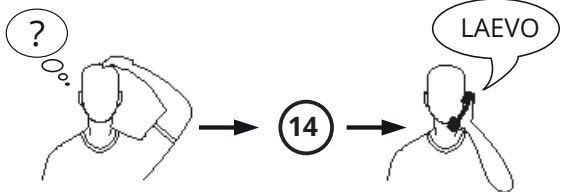
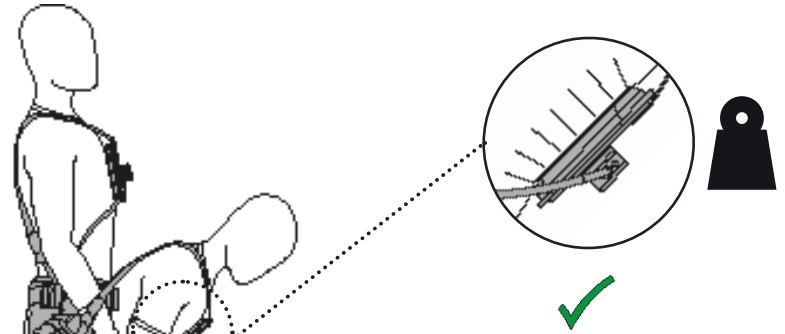
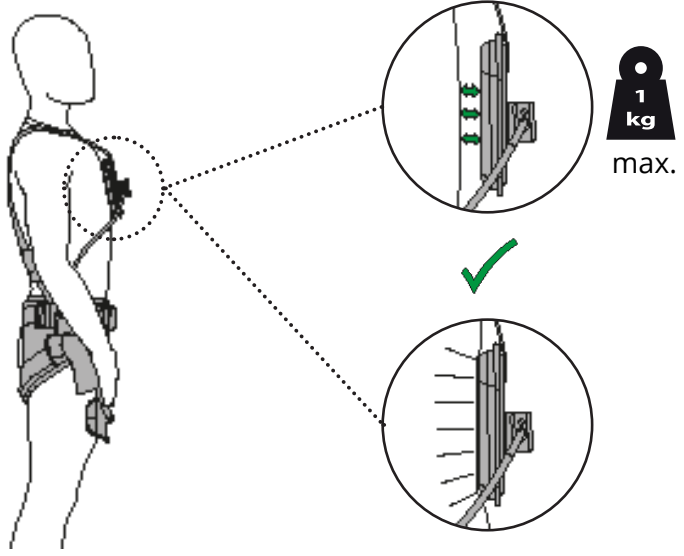

EN

# Checks

## QG-C

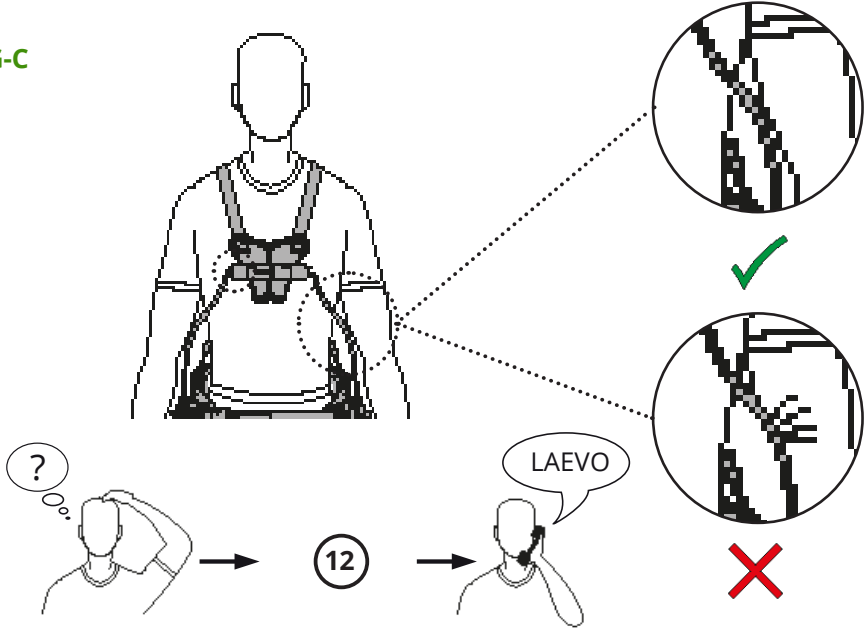

## QG-D

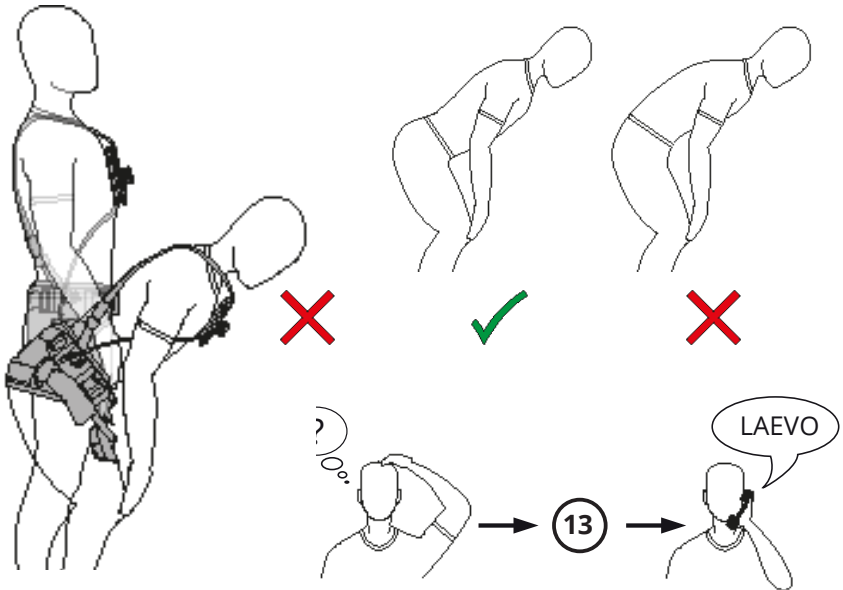

# Daily use

## QG-I

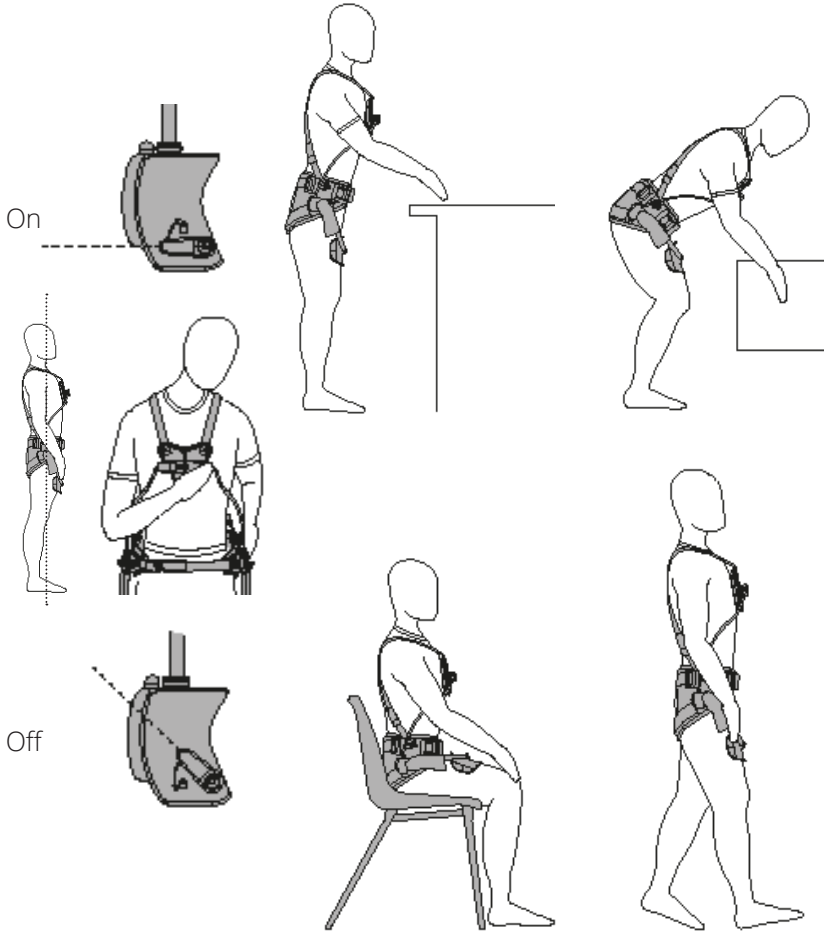

EN

## QG-II

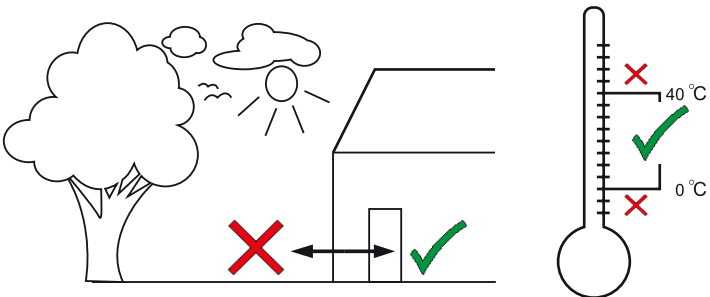

# Daily use

## QG-III

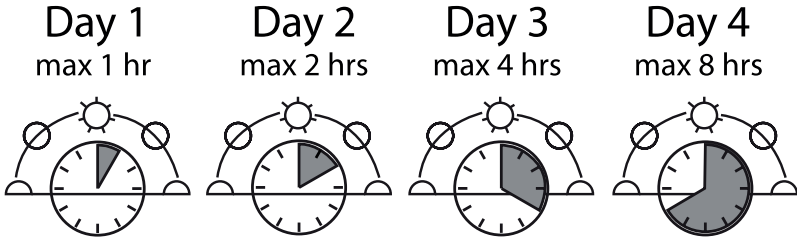

## QG-IV

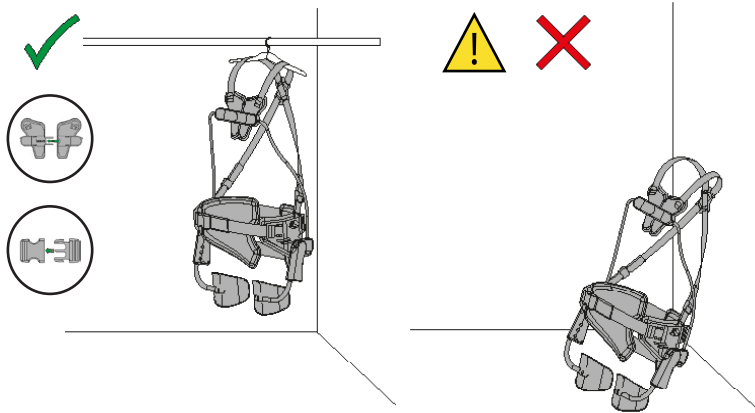

# Contact

---

Laevo B.V.  
Patrijsweg 30  
2289EX Rijswijk, the Netherlands  
[www.laevo-exoskeletons.com](http://www.laevo-exoskeletons.com)  
+31 15 30 20 025  
[info@laevo.nl](mailto:info@laevo.nl)

EN

