

laevo

EN

V2.57

Wearable back support
for repetitive bending and
bended posture

Quick Guide

February 2020

CE

Safety instructions & application

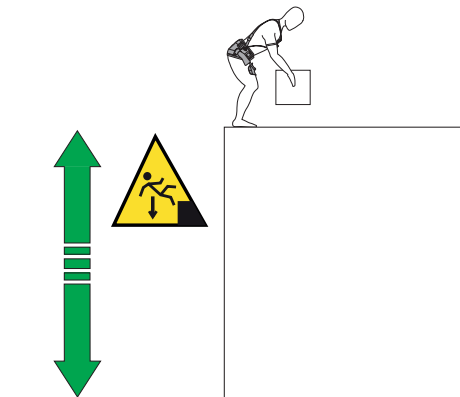
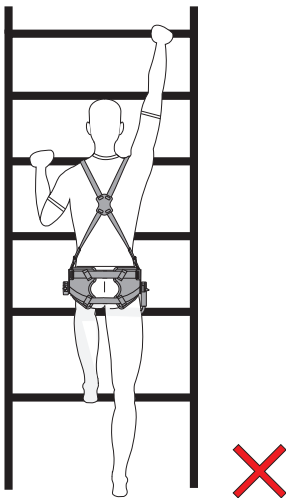
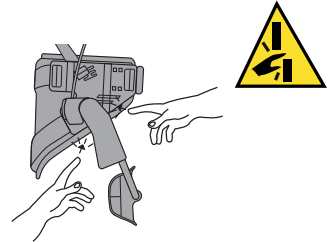
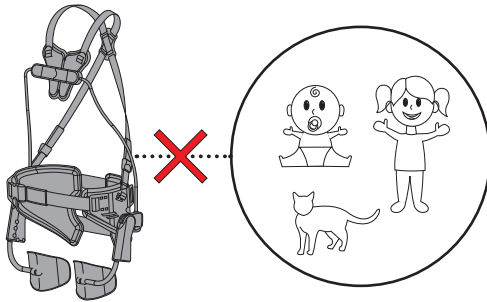
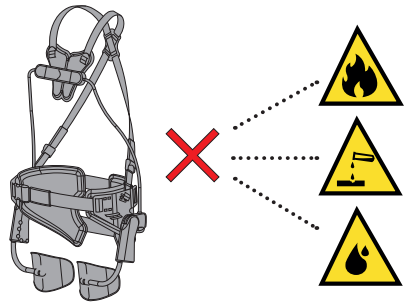
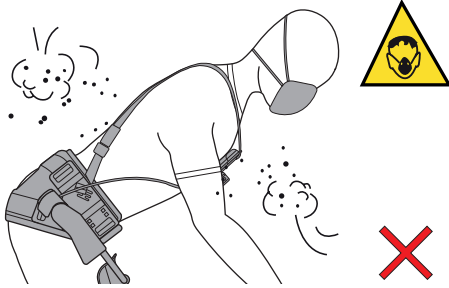

Installation

QG-1

EN

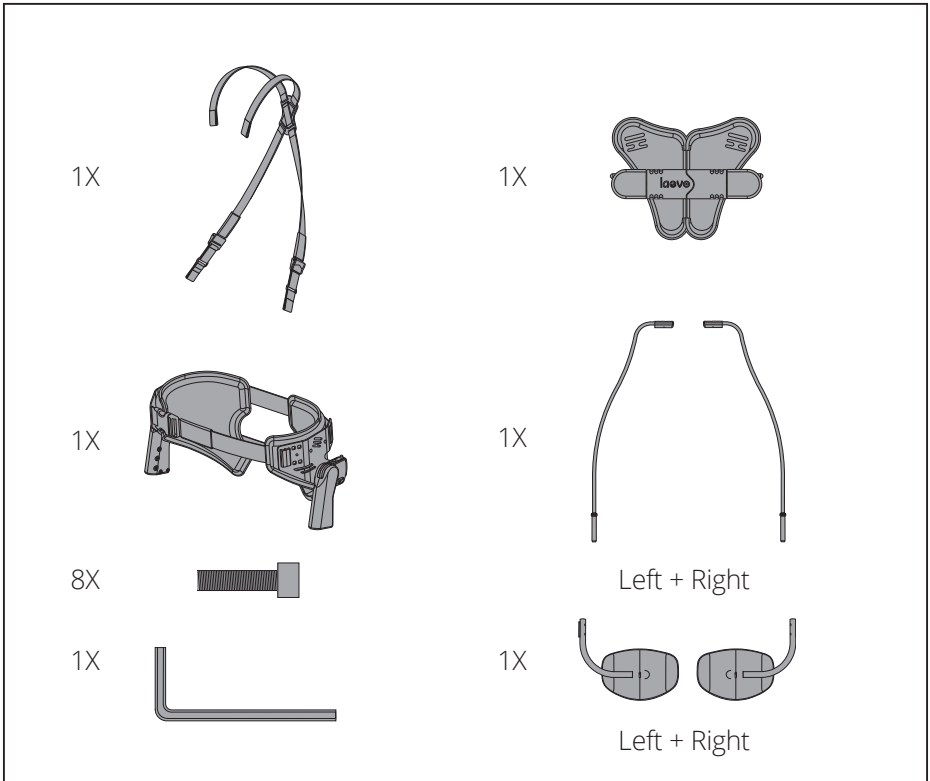
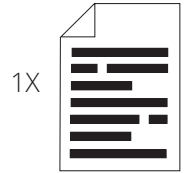
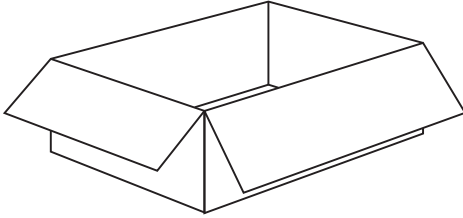

Installation

QG-2

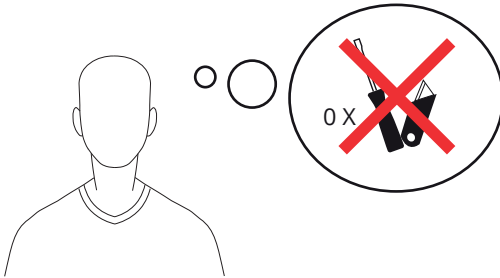
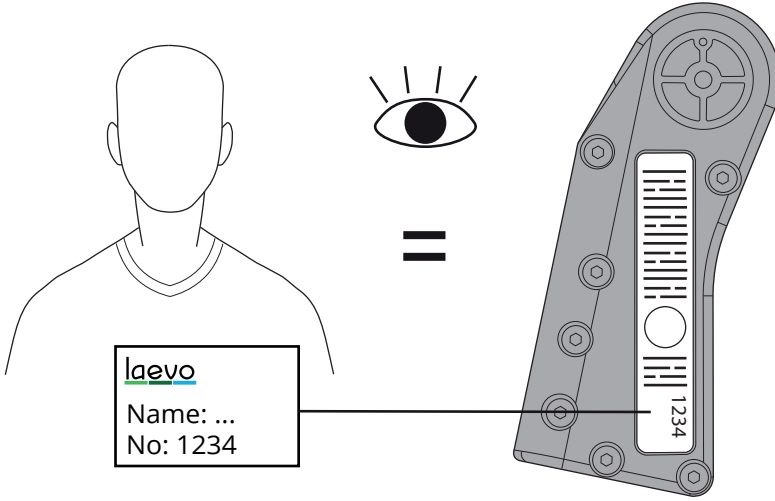

Installation

QG-3

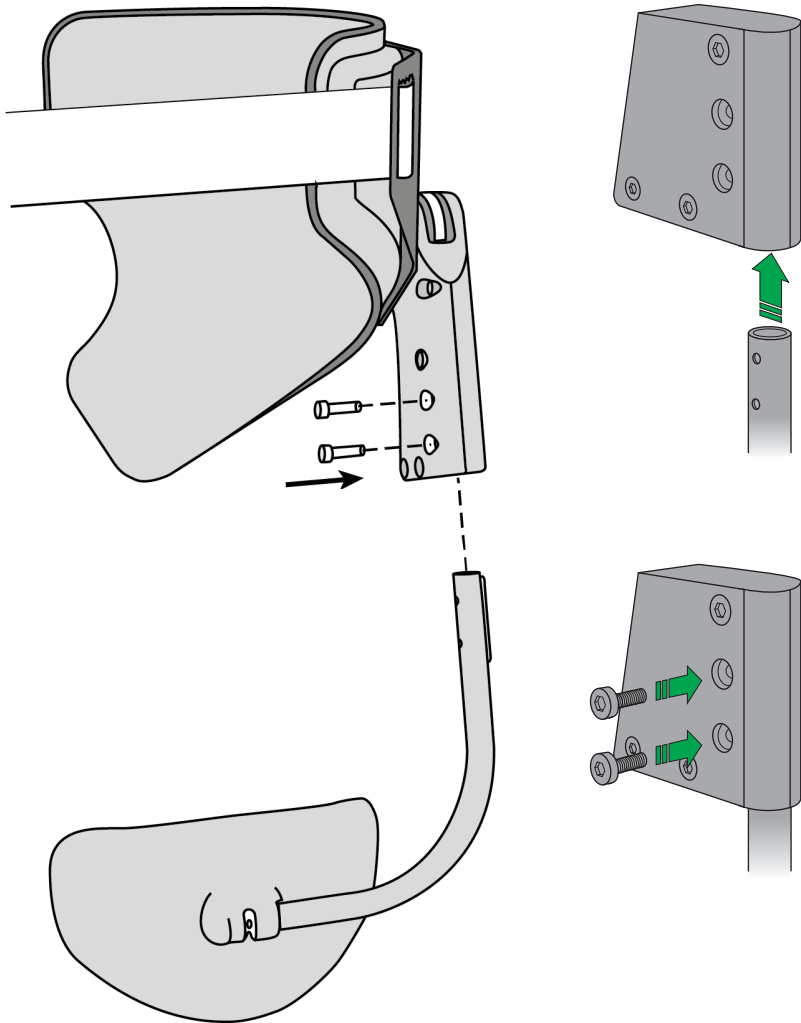

EN

Installation

QG-4

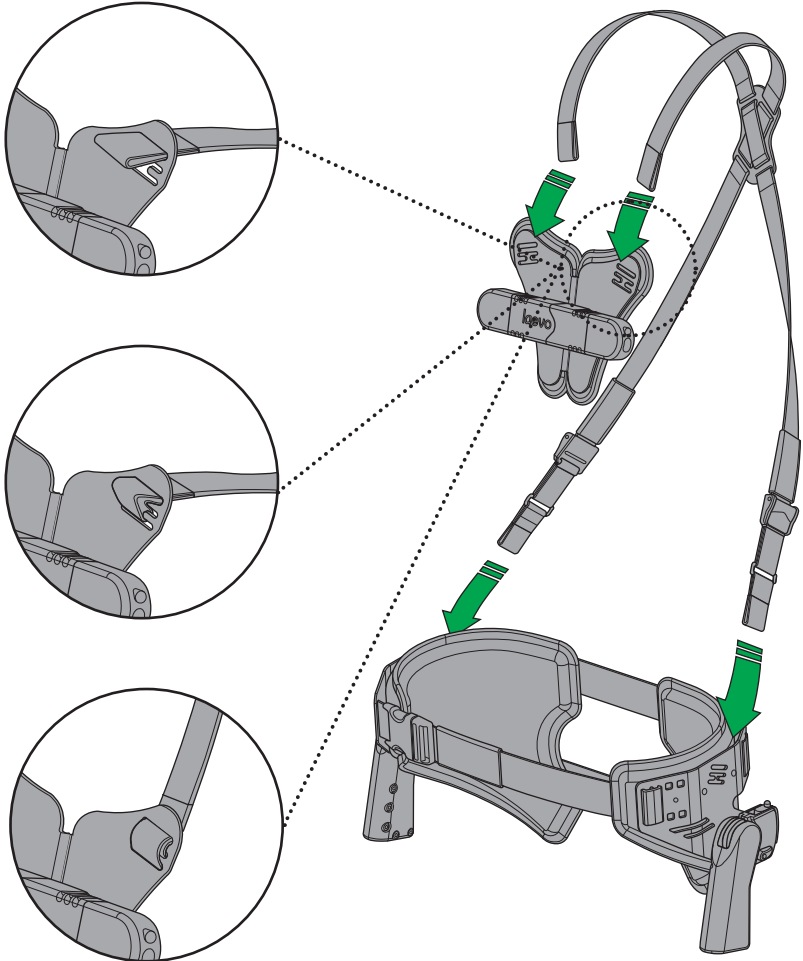

Installation

QG-5

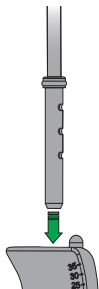
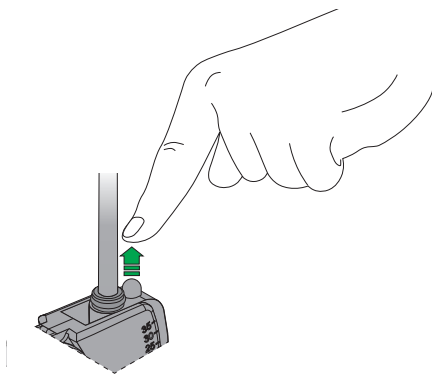
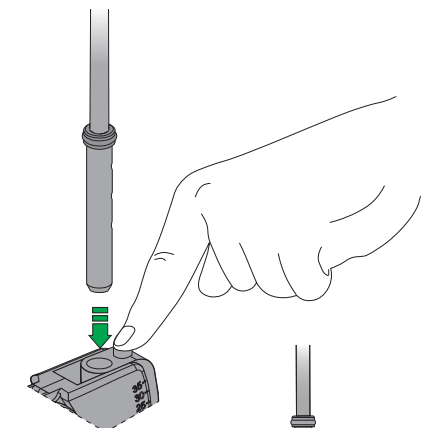
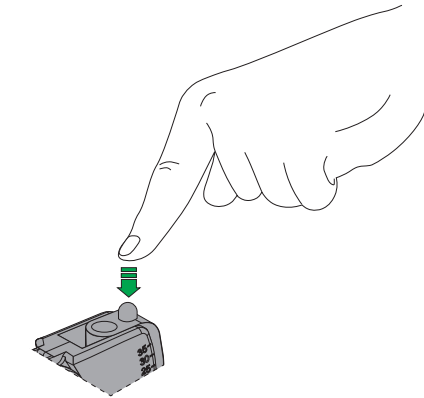
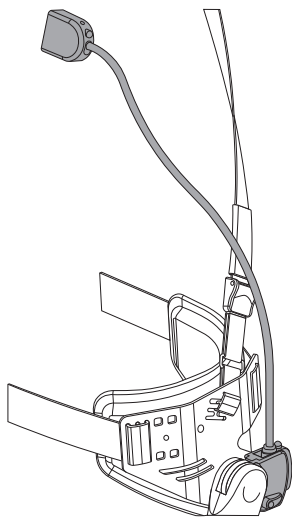

EN

Installation

QG-6

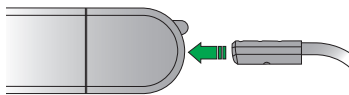
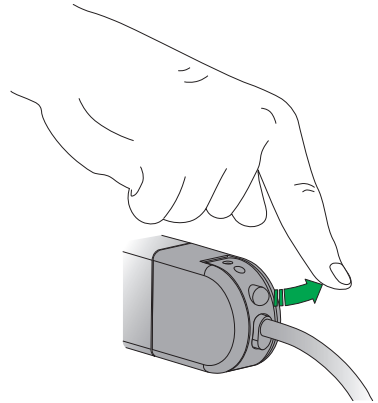
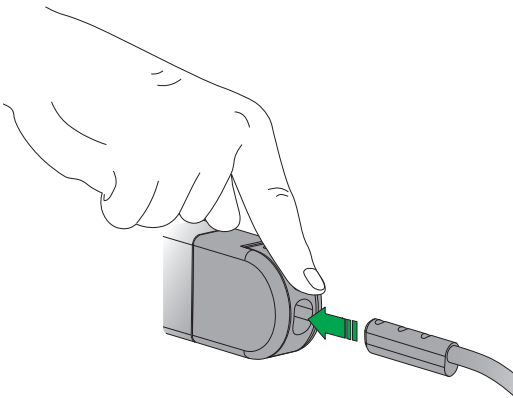
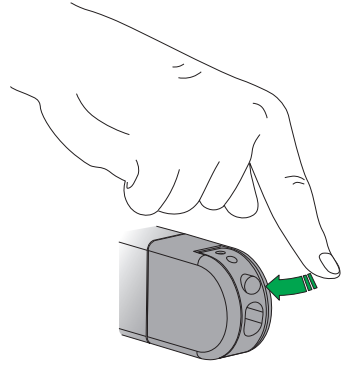
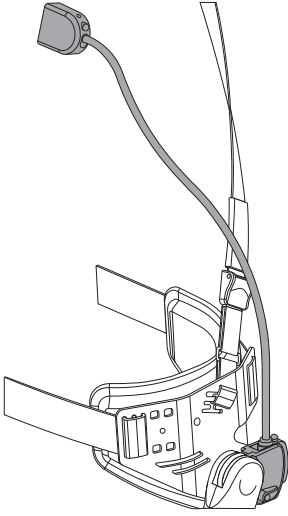

Fitting

QG-7

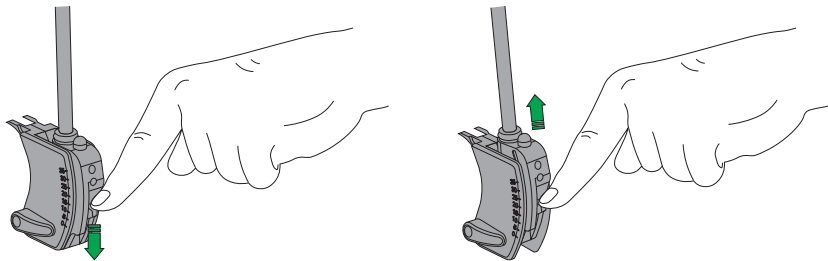

QG-8

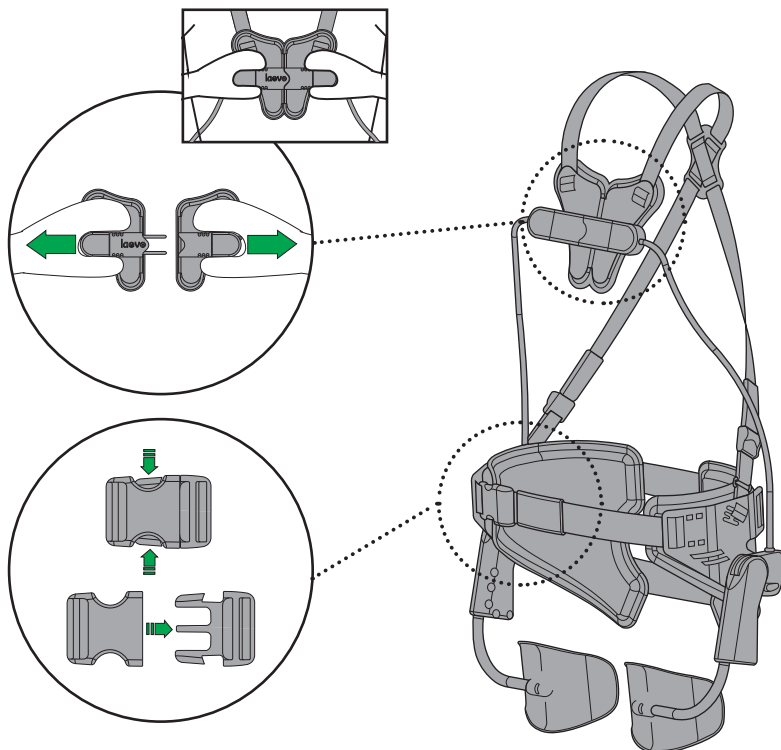

EN

Fitting

QG-9

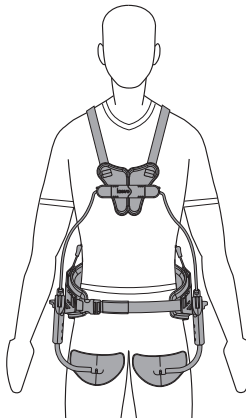
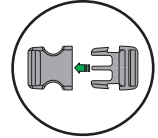
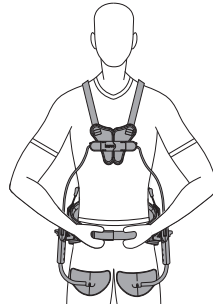
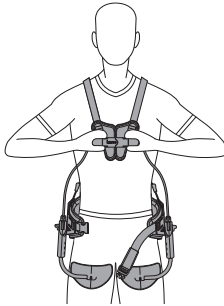
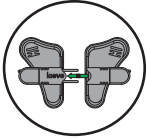
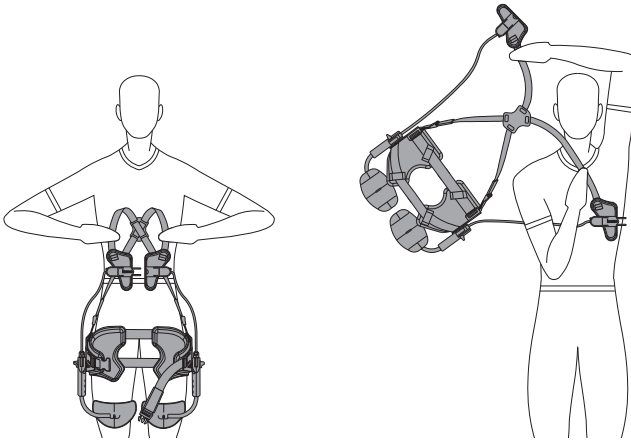

Fitting

QG-10

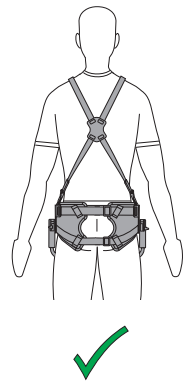
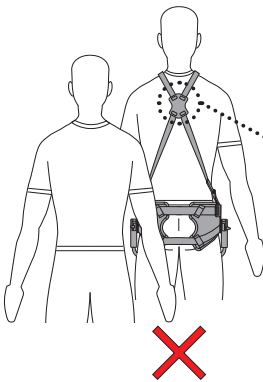
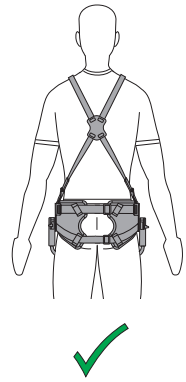
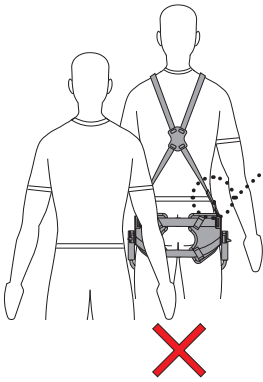
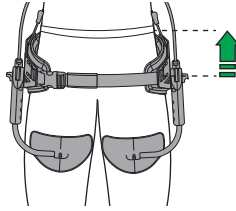

EN

Fitting

QG-11

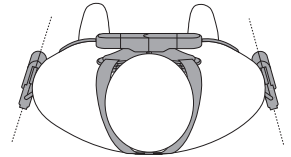
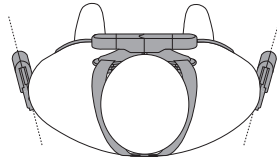
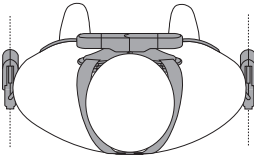
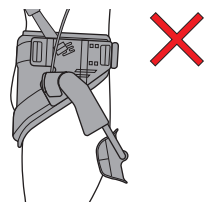
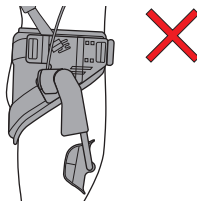
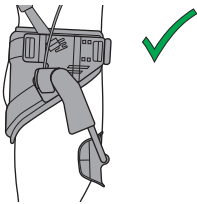
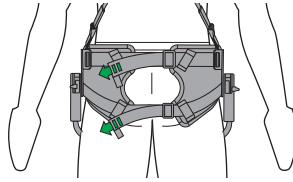

Fitting

QG-12

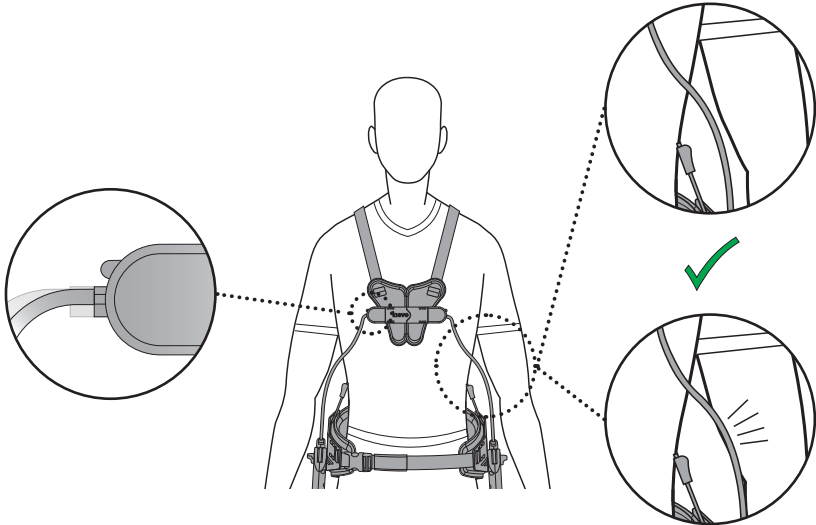

QG-13

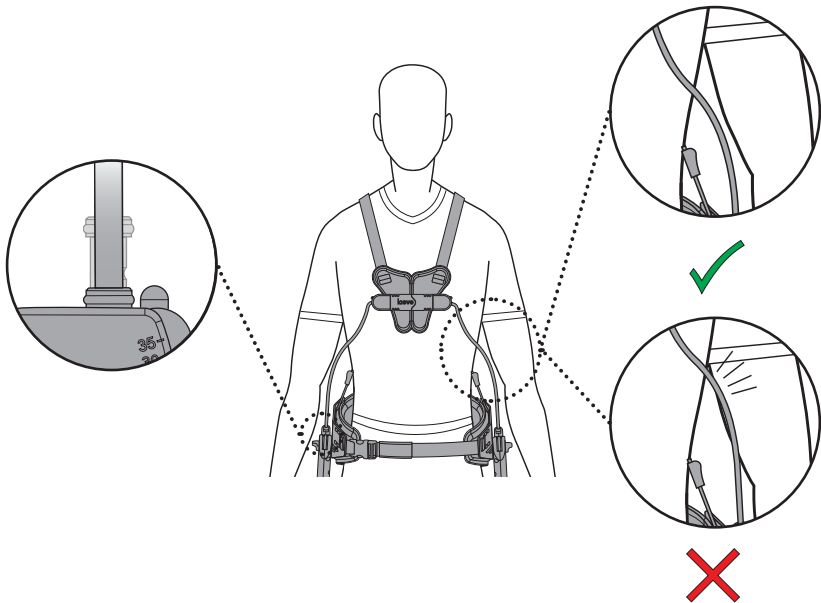

Fitting

QG-14

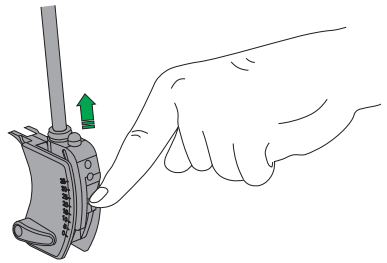
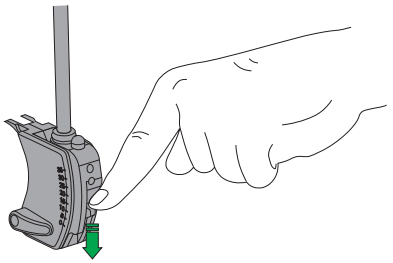
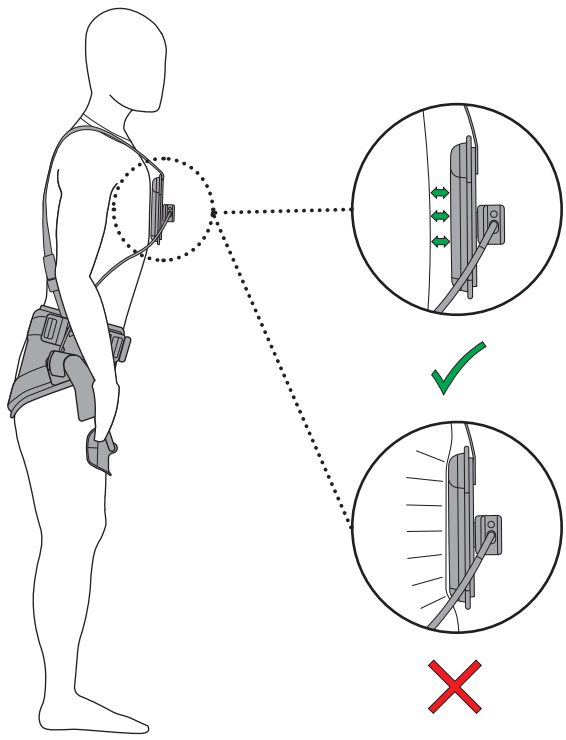

First use

QG-15

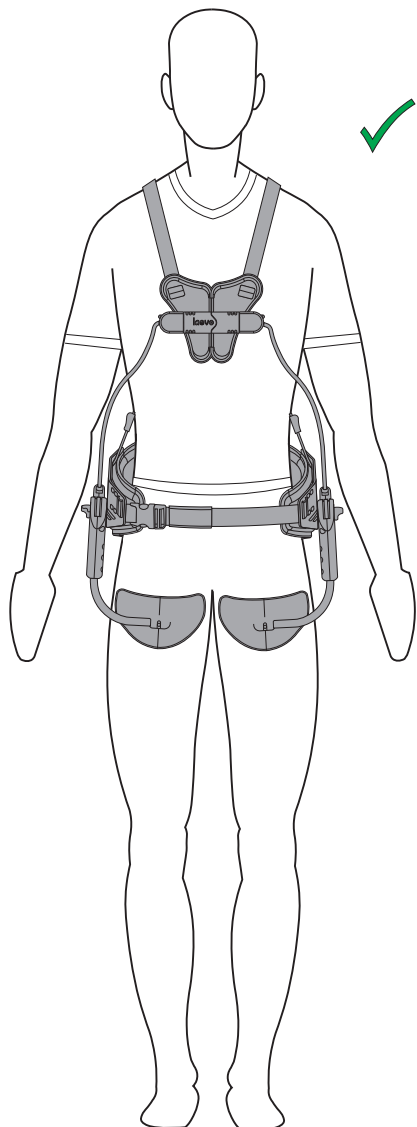

QG-16

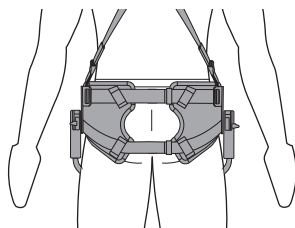
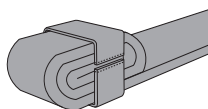
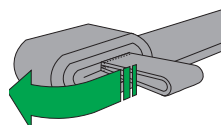
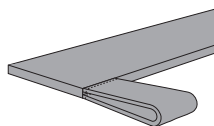
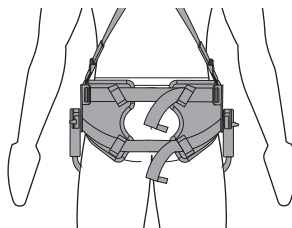

EN

Checks

QG-A

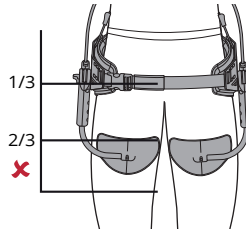
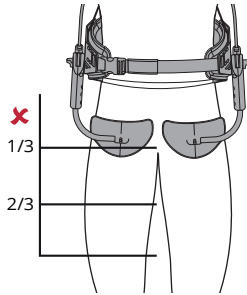
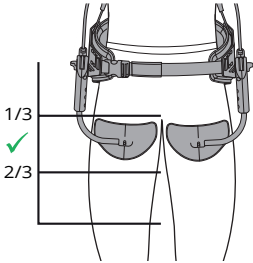
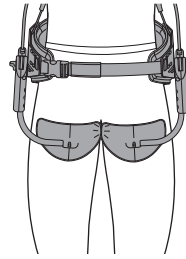
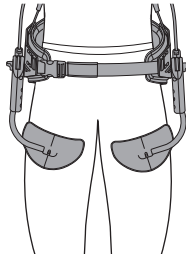
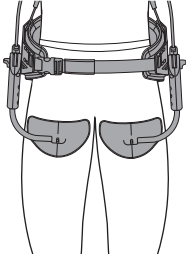

Checks

QG-B

EN

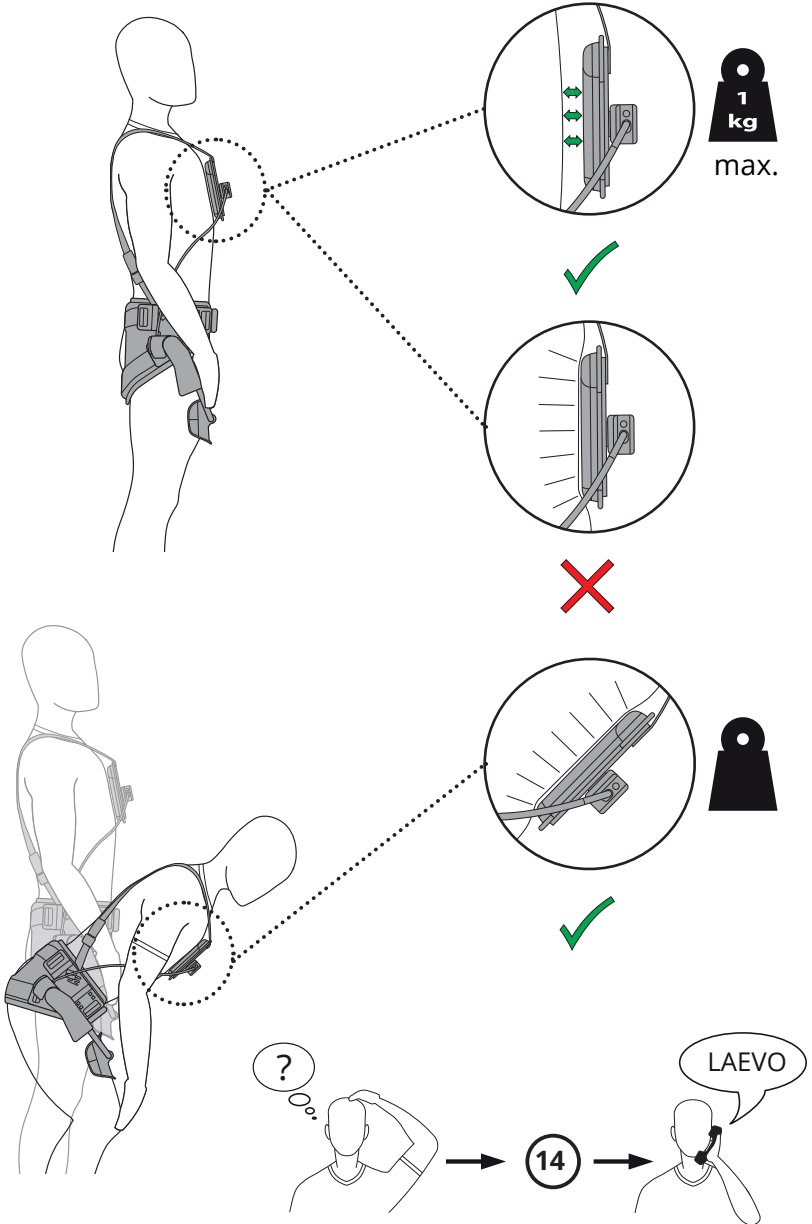

Checks

QG-C

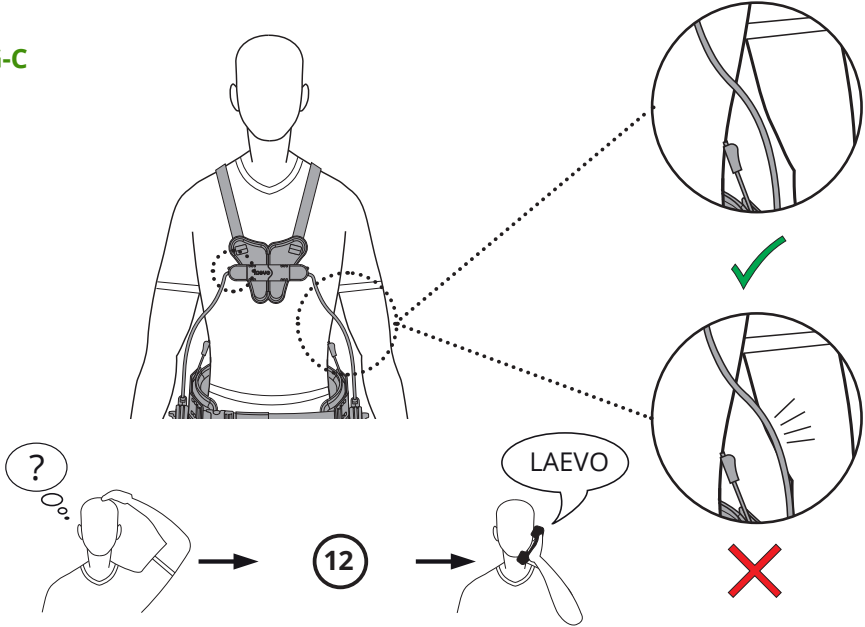

QG-D

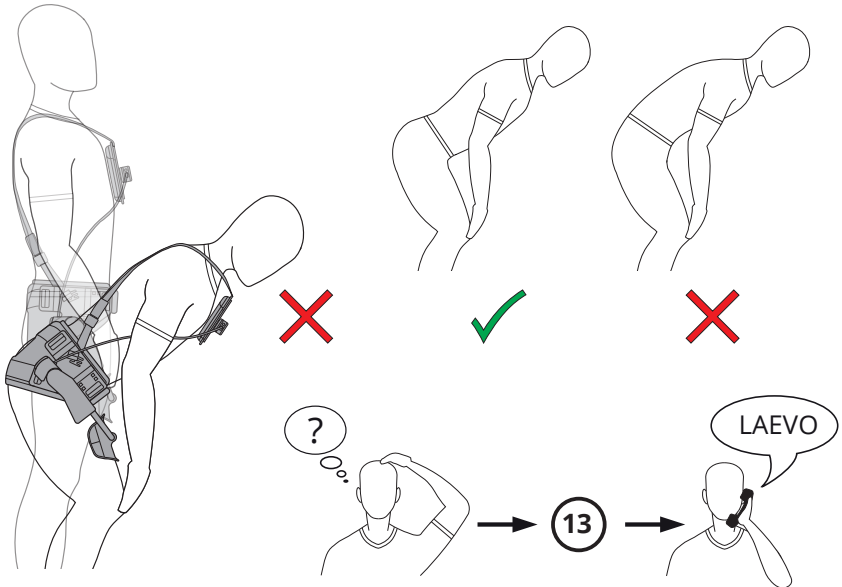

Daily use

QG-I

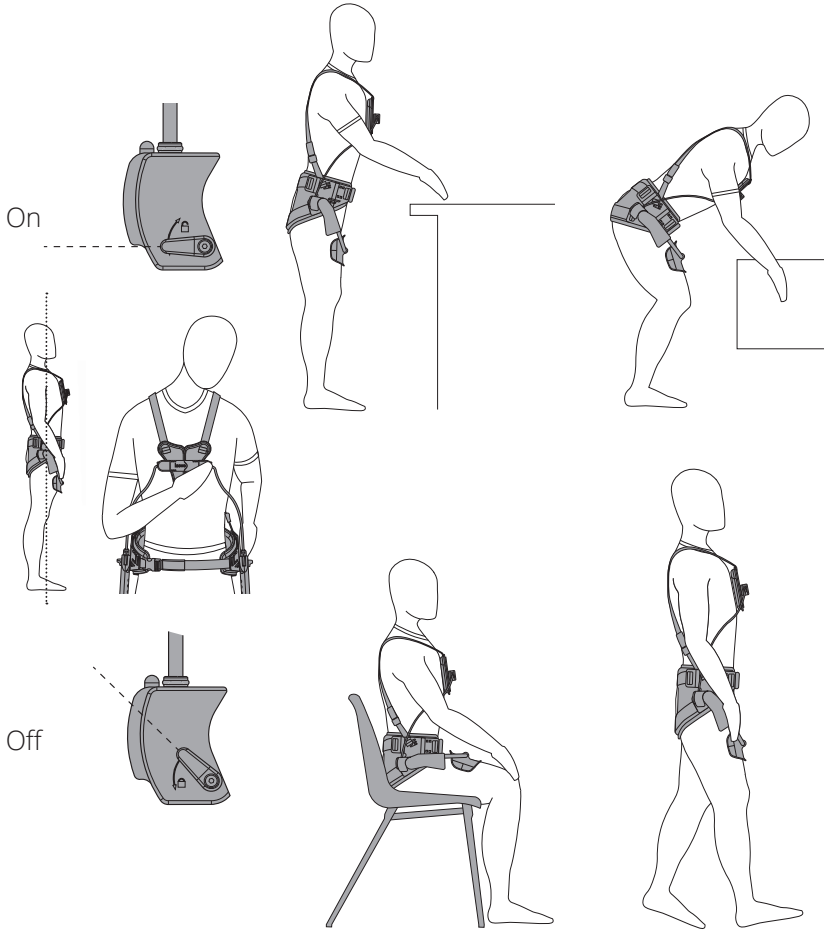

EN

QG-II

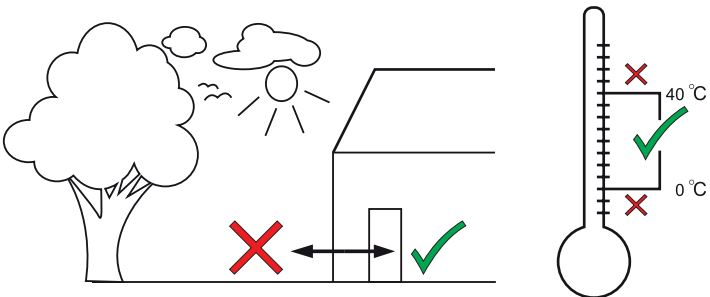

Daily use

QG-III

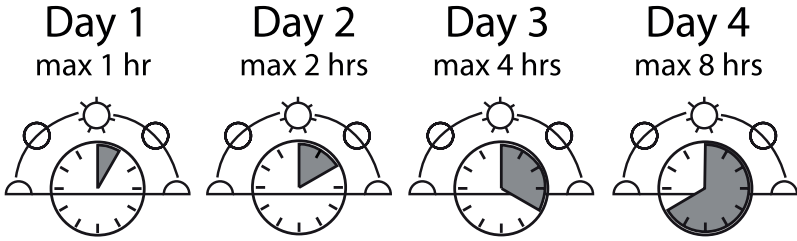

QG-IV

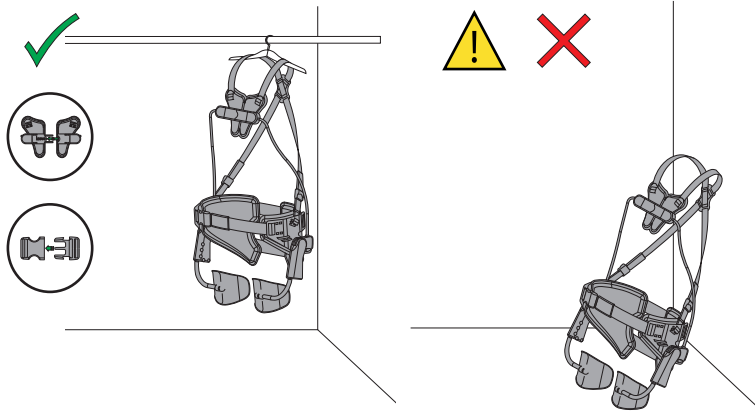

Contact

Laevo B.V.
Patrijsweg 30
2289 EX Rijswijk
The Netherlands
www.laevo.nl
+31 15 30 20 025
info@laevo.nl

EN

